



Autodesk
University
2007

AutoCAD® Architecture: When Walls Are Not Walls

David Driver, President 4D Architects, Ltd.

AB304-3 Many of us spend our days drawing walls, moving walls, and fixing “red circles of death.” We never stop to ask the question “When is a wall not a wall?” With AutoCAD Architecture, discover how to use walls for more than just vertical partitions. See examples of using walls to create casework, and learn other techniques you may never have known existed.

About the Speaker:

David is a registered architect, and has worked in architectural firms since 1984. He has experience on a range of projects including civic, commercial, and single and multifamily housing. In addition to ongoing production work, David is a consultant on CAD standards and the implementation of Autodesk Building Information Modeling products. An Autodesk Certified Instructor since 1997, David teaches intensive short courses at several Autodesk Authorized Training Centers throughout the U.S. His continuing practice of architecture guarantees his class will target the common tasks and problems encountered in daily office routines.



david@daviddriver.com

Autodesk®

Outline, Expectations, Prelude and Introduction

Welcome to **When Walls are not Walls** Autodesk University 2007. My name is David Driver. I am architect licensed in Arizona and BIM consultant. I have been beta testing, using, teaching, and implementing Architectural Desktop (ADT) / AutoCAD Architecture (ACA) since 1998 and Revit Since 2003 throughout the US.

Having used the software since the earliest releases, I have often found a need to represent objects not found in the standard catalog such as curbs. At other times I have seen an advantage in utilizing one object to represent another such as using a wall to represent casework that has a tendency to change often during the design phase of a project. I put this class together to put many of these ideas into one location. As I was creating this class, I gave it an *Intermediate* level designation. While some of the topics I cover will be basic to many of you, when pushing AEC objects outside their expected behavior, it helps if you are intimately familiar with all of the parameters of both the object and its style including their display properties. However, by the time the class was up on AU web site it had become an introductory level class. Regardless, here are many tools developed for working with walls a plethora of ways to use them to create non wall objects in ACA. This class will focus on only few of them.

 <p>Part 1: Walls as Layout Tool:</p>	<p>In this section, I will describe the use of the layout curve and how it applies to a wall. In this instance the wall will be a wall, however, it will also be a controlling mechanism for a repeating layout of plumbing fixtures or floor joists and studs.</p>
 <p>Part 2: Vertically Stacked Walls:</p>	<p>These wall types take advantage of the portion of the wall style that allows you to set the start and end offsets in the z direction. The exercise in this section will illustrate how to create a casework wall similar to those found in the content browser. Additional samples shown will be foundation walls.</p>
 <p>Part 3: Walls with Sweeps:</p>	<p>A sweep in essence is any closed polyline extruded along a wall which replaces one of the wall components. As such, any linear element curved or not can be represented by a wall with a sweep. The exercise in this section will cover creating a curb and gutter for a site plan. The additional samples provided will be a rod and shelf and...</p>

For each of these topics are further separated into 3 sections

Concepts and Terminology

Examples : Installed (style or content that comes with the software)

David's Examples (from the dataset you can download from my web site or AU-Online

Exercise that demonstrates how I came up with David's Examples.

Questions and answers: Because of the varied nature of the 3 main topics I will take a few questions after each topic.

Extra Credit! Curtain Walls: If time allows, I will show a few examples of *walls which are not walls* in every sense of the word. Using the Curtain wall object (separate type of AEC object entirely). This section consists primarily of examples because working with the curtain wall object/style is a class entirely to itself. If you want more information on curtain walls, I taught two classes this year on curtain walls. Feel free to download the datasets and pdf's from either my web site or the AU-Online web site:

AB210-3 Opening the Door to Curtain Walls in AutoCAD® Architecture, Part I

AB214-3 Opening the Door to Curtain Walls in AutoCAD® Architecture, Part II

Part 1: Walls as Layout Tool

While not truly a built object, I feel this topic falls into the “When Walls are not Walls” category as the layout tool allows you to use the wall to anchor other objects to it. Once the wall becomes a layout curve, as the wall moves lengthens or shortens the objects anchored to the layout curve are also modified.

Concepts and Terminology

I am including a brief overview of Anchor’s concepts and terminology here rather than the addenda as in my classes I have found that many experience ACA users have with layout tools and their functions.

Anchor Concepts:

Broadly put, an anchor is a relationship between two ACA objects. Anchors come in many different forms. Some anchors are automatic and are so integrated into the software nobody thinks about them. A basic anchor occurs when a door is added to a wall. When the wall is moved the door moves with it because it is anchored to the wall. The specifics of this anchor are accessible from the worksheet near bottom of the door’s properties page.

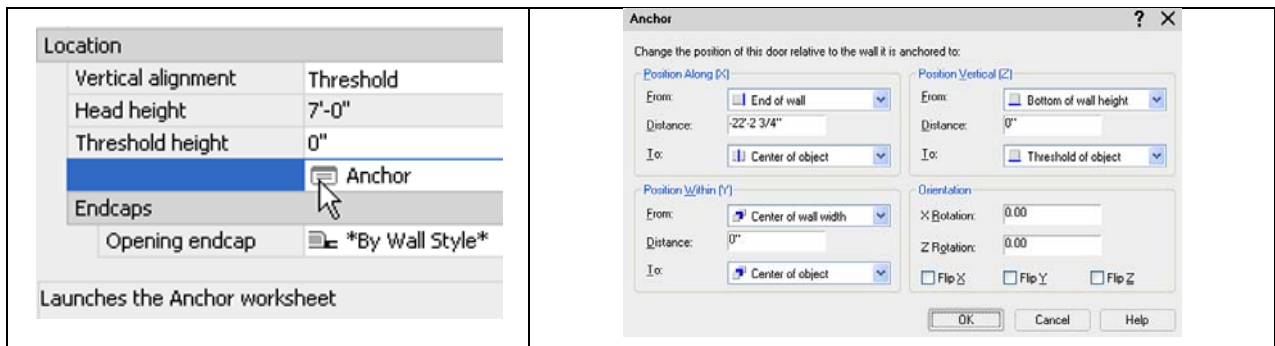

The other general type of anchor is a manual anchor. These types of anchors require you to specify the object to anchor and the layout tool to anchor the object to. The tools to create these types of anchors are found in the Content Browser’s **Stock Tool Catalog > Parametric Layout and Anchoring tools**. Within this category in the catalog are three distinct types of tools. These tools are organized below in how they behave, not the order they appear in the stock tool catalog.

Layout Curve Layout Grid 2D Layout Grid 3D	Cell Anchor Node Anchor Leader Anchor Volume Anchor	Object Anchor Curve Anchor
<p>Layout tools establish a framework to anchor things to.</p>	<p>Anchor tools provide the function of anchoring object to the layout tools</p>	<p>These two tools allow you to simply anchor one object to another without the use of a layout tool</p>

Terms:

There are a few specific terms that are new or used differently from general AutoCAD and Architectural Desktop use

Node:

The Anchor point for an ACA object on a layout tool, curve, 2d grid or 3d grid

Cell

An anchor point for a layout grid 2D or 3D

Layout Curves and Grids

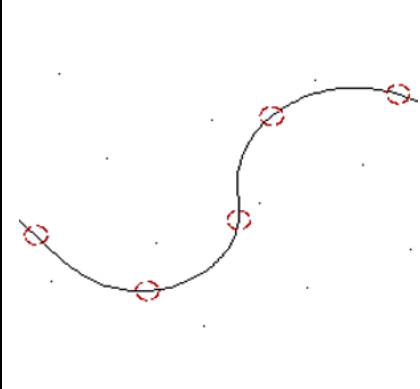
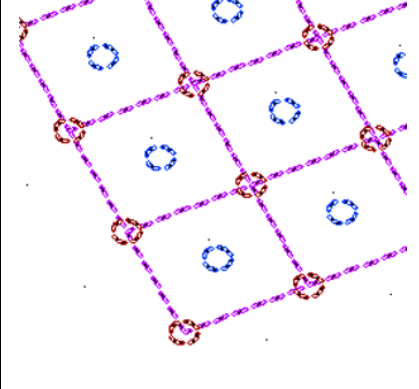
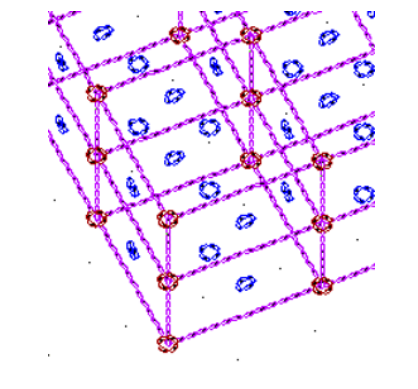
<i>Layout Curve</i>	<i>Layout Grid 2D</i>	<i>Layout Grid 3D</i>
		
A Layout Curve is always applied to an existing linear element. In this case it has been applied to a polyline.	A Layout Grid is a separate ACA object.	A Layout Grid 3D is a separate ACA object
The Display Representation has been modified to show the layout curve nodes as visible and red.	The Display Representation has been modified to show the layout curve nodes as visible and red and the layout cells as visible and blue.	The Display Representation has been modified to show the layout curve nodes as visible and red and the layout cells as visible and blue.
A Layout curve has only NODES.	A layout grid 2D has both node anchors and cell anchors	A layout grid 3D has both node anchors and cell anchors that can be made visible.
	Both Structural Grids and Ceiling Grids are derived from the 2D layout grid. As such you can use the node or cell anchor tool with either of these ACA object types.	The Volume anchor tool will attach an object to the center of each 3D grid, but there is no display component that allows you to see this location.



Installed Examples

There are a few examples of a layout curves installed with the software. These are found in the Architectural Design Tool Catalog: Design > Mechanical > Plumbing Fixtures > Layouts. In particular, the Layouts Lavs (2) Lavs (3) and Lavs (4) utilize the layout curve as applied to a wall used as a counter.

Note that although the full restroom layouts also have lavatories in them unlike previous versions these do not use the layout curve to automatically adjust spacing, but you can add it after the fact if you wish.

David's Examples:

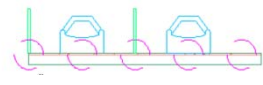
Within the Dataset drawing AB304-3_Walls not Walls part 1.dwg there are a few samples of walls that act as a layout curve

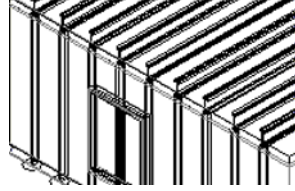
			
This sample shows the layout curve method Space Evenly.	This sample shows the layout curve method Repeat.	This sample shows the layout curve method Manual.	This example shows studs and joists assigned to the same layout nodes

Some notes on the examples

You CAN assign multiple layout curves to the same wall if you wish. I could have done all of the three restroom layout curves on the same wall and had the same end result. I have kept them as layout curves on separate walls for clarity.

In the Space Evenly example there are two layout curves in this example. One is assigned to countertop wall and controls the lavatories the other locks the countertop to the carrier wall.

In the studs and joists example, two different objects are assigned to each node of a layout curve with repeat 24" spacing.

Exercise: Attaching Floor Joist at 16" O.C. to Wall as Layout Curve

This exercise leads you through:

- Assigning a layout curve to a wall
- Anchoring a joist to a node
- Using the Anchor worksheet to adjust the location and rotation of the joist

Assigning a layout curve to a wall

In this part of the exercise you will use the Layout Curve tool create the layout curve, assigning it to a wall.

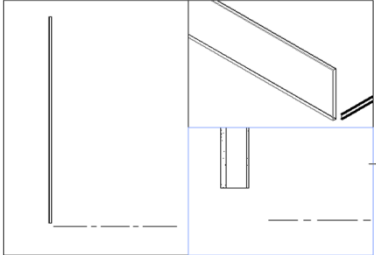
<i>Step</i>	<i>Image</i>	<i>Comments</i>
Open the dataset drawing AB304-3_Walls not Walls Part 1.dwg and make LAYOUT CURVE EXERCISE layout tab current. Make the left viewport current.	LAYOUT CURVE EXERCISE: ATTACHING FLOOR JOISTS AT 16" O.C. TO WALL 	The wall and joist are already provided for you.
Open the Content Browser and navigate to the Stock Tool Catalog> Parametric Layout and Anchoring Tools category	Stock Tool Catalog Catalog Top < Parametric Layout & Anchoring Tools	

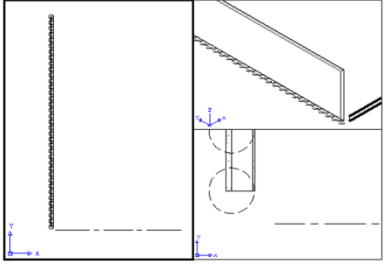
Eye drop the Layout Curve tool into the left viewport	 Layout Curve Defines an object as a layout curve on which to anchor objects.	Leave the content browser open. You will need it in the next section of the exercise.
Pick the wall	After you drop the tool into the drawing the command line prompts you to "Select a curve:" any linear element can act as the basis for a layout curve.	This includes walls, lines, polylines, anything linear.
Type R and [enter] [Enter] 2x	This sets the layout mode to repeat.	By pressing the Enter key twice you skip by setting a start and end offset for the first and last nodes on the layout curve.
Type 16" and [enter]		This sets the spacing of the repeat mode to 16"
Save your work		The wall now shows the layout curve's nodes at 16" O.C. along the entire length of the wall.

Anchoring a joist to a node

In this part of the exercise you use the Node tool to attach a joist to the node of the layout curve.

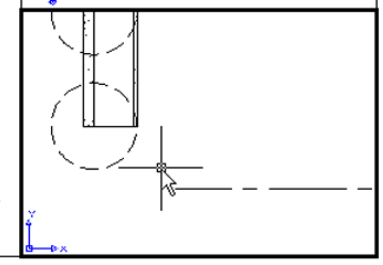
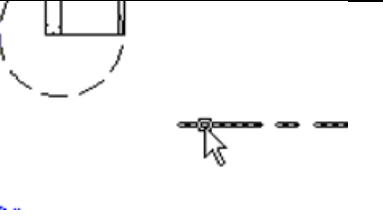
<i>Step</i>	<i>Image</i>	<i>Comments</i>
Make the lower right viewport current		The joist has already been placed in the drawing
From the same page of the Content Browser, Eye drop the Node Anchor tool into this viewport		
Right click and select Attach object from the pop up menu		
Select the joist (the centerline in plan) as the object to be anchored.		

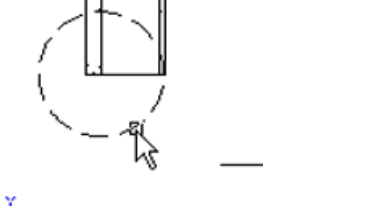
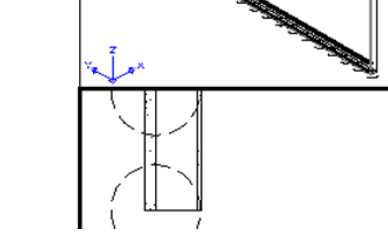
<p>Select the lower node as the node to anchor to. [Enter] to end the command.</p>		
<p>Save your work</p>		<p>The joist is indeed now anchored to the node, but has taken on the node's orientation. This causes the joist to rotate around 90 degrees</p>

Using the Anchor worksheet to adjust the location and rotation of the joist

In this section you will use the anchor worksheet to adjust the location of the joist in relationship to the node it is anchored to and copy it to the other nodes.

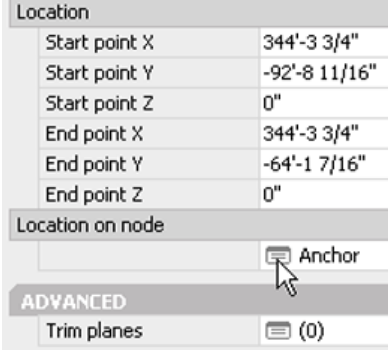
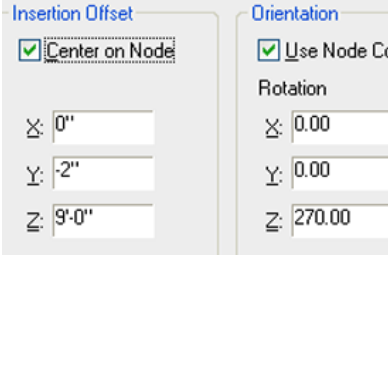
<i>Step</i>	<i>Image</i>	<i>Comments</i>																						
<p>Make the upper right viewport current Select the joist Open the joist's properties page</p>																								
<p>Near the bottom of the properties page you will see a category "location on node" and an anchor worksheet. Click this worksheet icon</p>	 <table border="1" data-bbox="618 1102 1003 1461"> <tr><th colspan="2">Location</th></tr> <tr><td>Start point X</td><td>344'-3 3/4"</td></tr> <tr><td>Start point Y</td><td>-92'-8 11/16"</td></tr> <tr><td>Start point Z</td><td>0"</td></tr> <tr><td>End point X</td><td>344'-3 3/4"</td></tr> <tr><td>End point Y</td><td>-64'-1 7/16"</td></tr> <tr><td>End point Z</td><td>0"</td></tr> <tr><th colspan="2">Location on node</th></tr> <tr><td></td><td><input type="checkbox"/> Anchor</td></tr> <tr><th colspan="2">ADVANCED</th></tr> <tr><td>Trim planes</td><td><input type="checkbox"/> (0)</td></tr> </table>	Location		Start point X	344'-3 3/4"	Start point Y	-92'-8 11/16"	Start point Z	0"	End point X	344'-3 3/4"	End point Y	-64'-1 7/16"	End point Z	0"	Location on node			<input type="checkbox"/> Anchor	ADVANCED		Trim planes	<input type="checkbox"/> (0)	<p>While there are many right click tools available to you for anchored objects, I find this worksheet page invaluable in modifying the object in relationship to the node.</p>
Location																								
Start point X	344'-3 3/4"																							
Start point Y	-92'-8 11/16"																							
Start point Z	0"																							
End point X	344'-3 3/4"																							
End point Y	-64'-1 7/16"																							
End point Z	0"																							
Location on node																								
	<input type="checkbox"/> Anchor																							
ADVANCED																								
Trim planes	<input type="checkbox"/> (0)																							
<p>Set the insertion offsets and Orientation Insertion offsets X=0 Y = -2" Z = 9' Orientation Z= -90 or 270 Click OK</p>	 <table border="1" data-bbox="618 1465 1003 1839"> <tr><th colspan="2">Insertion Offset</th></tr> <tr><td><input checked="" type="checkbox"/> Center on Node</td><td></td></tr> <tr><td>X: 0"</td><td></td></tr> <tr><td>Y: -2"</td><td></td></tr> <tr><td>Z: 9'-0"</td><td></td></tr> <tr><th colspan="2">Orientation</th></tr> <tr><td><input checked="" type="checkbox"/> Use Node Co</td><td></td></tr> <tr><td>Rotation</td><td></td></tr> <tr><td>X: 0.00</td><td></td></tr> <tr><td>Y: 0.00</td><td></td></tr> <tr><td>Z: 270.00</td><td></td></tr> </table>	Insertion Offset		<input checked="" type="checkbox"/> Center on Node		X: 0"		Y: -2"		Z: 9'-0"		Orientation		<input checked="" type="checkbox"/> Use Node Co		Rotation		X: 0.00		Y: 0.00		Z: 270.00		<p>Remember the native orientation of almost all ACA objects is drawn from left to right in the world UCS.</p>
Insertion Offset																								
<input checked="" type="checkbox"/> Center on Node																								
X: 0"																								
Y: -2"																								
Z: 9'-0"																								
Orientation																								
<input checked="" type="checkbox"/> Use Node Co																								
Rotation																								
X: 0.00																								
Y: 0.00																								
Z: 270.00																								
<p>From the same page of the Content Browser, Eye drop the Node</p>																								

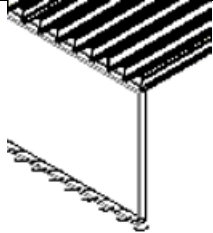

Anchor tool again into the top right viewport		
Right click and select Copy to each Node		
Click the joist as the object to copy		
Click one of the nodes at the layout tool to copy to		
Right click and select Yes to skip the nodes that already have something assigned to them		
Save your work		The joist is now associated with all nodes on the layout curve

Tips and Tricks and other thoughts

Currently (and since release 1), ACA objects can have only 1 relationship (anchor) per object. This has implications when you are anchoring one object to another specifically when the object you are anchoring already has an anchor. I.e. if you try anchoring a door that is within a wall to a layout curve node, it will break its relationship with the wall. This also prevents you from anchoring one end of the joist from one wall and the other end of the joist to another wall.

When Anchoring walls to nodes, the wall will anchor by default to the center of the wall. Changing the length of the wall will change the centerpoint and create havoc with your carefully planned offsets. Put your walls inside a block and then anchor the block to the node, much easier.

Part 2: Multi-Component Vertically Stacked Walls

Vertically stacked walls are wall styles that take advantage of the ability to set a vertical start and end point to each component with the style. Any built object that has rectilinear elements stacked on top of each other can be represented with a wall style created this way.

Fundamental Concepts and Terms

Drawing Walls and Wall Direction

The generic orientation of an ACA object is drawn from left to right in the world UCS. If you are working with many ACA objects you will see Offset X and Offset Y. These parameters do not make sense unless you imagine the object in this basic orientation.

Generally all the walls supplied with the software are created to be drawn in the clockwise direction. This includes both the interior and exterior wall styles.

Given the above two concepts, then when working with wall components, a wall drawn from left to right is the top (or north side) of a rectangular building drawn in plan view. Positive offsets and measurements are to the outside of the building. Negative offsets are to the inside of the building.

Baseline

The word Baseline has two uses in regard to walls: Baseline justification and the Baseline as a vertical orientation for the components of the wall. The meaning of Baseline in both of these cases is the same. It is a line defined between the start pick point and the end pick point that create the wall.

Baseline justification is one of the properties of a wall. Given the same start and end pick points, different styles will position the wall differently depending on the intent of the designer of the wall style. A standard style wall baseline justified looks exactly like a center justified wall. A CMU wall style will likely be justified to the exterior face of the CMU and a stud wall to the exterior face of the stud. This is entirely controlled by the *Edge Offset* and *Width* parameters of the + and end segment of a wall style component definition. In this case it means exactly the same thing as above, a line drawn between the starting and ending point of the wall. However in this case, the component can be adjusted vertically in reference to this imaginary line.

Wall Components:

Index	Name	Priority	Width	Edge Offset
1	Casework	1200	-1'-10"	0"

Component parameters Width and Edge Offset within the style dialog box are measured from the baseline of the wall.

BW within a wall component definition

Name	Priority	Width	Edge Offset
Unnamed	1	BW	$BW * -0.50000$

Some styles will have BW or some equation of BW with the Width, and or Edge offset. This is just a variable that takes whatever width is entered in the properties and passes it on to the components in the wall.

Wall Clean Ups

The following parameters control how walls clean up:

- Graph line and Clean-Up radius: Graph lines must touch or cross another walls cleanup radius or graph line for the walls to clean up. [Cleanup Circles and Wall Graph lines]
- Component priority: The priority assigned to a component is used to calculate whether one component in a wall cleans up with a component in another wall [Wall Cleanups and

Priorities]. Please note that even if components are assigned different component numbers the software will still run through the calculations of whether these two components will clean up. Use Clean up groups to prevent the software from even trying to clean up different walls such as the cabinetry components used in the following examples

- Clean-Up Groups: Walls assigned different cleanup groups will not clean up with each other. [Cleanup Group Definitions]
- Z-Elevation of wall: Walls placed on different Z elevations will never clean up

Display concepts and terms

Cut Plane: Generally stored in the display configuration, this variable is applied as style override to the display properties of customized styles such as those discussed in this paper.

ACA objects rotated out of the X-Y plane will generally use the plan display representation when viewed from the top. But this may not be what you expect

Installed Content:

A typical install of Architectural Desktop will give you some examples of vertically stacked walls. Accessed through the Content Browser's Design Tool Catalog, the Walls>Casework and Concrete divisions include these types of vertically compound walls. Both the Casework and Concrete categories contain vertically stacked wall styles.

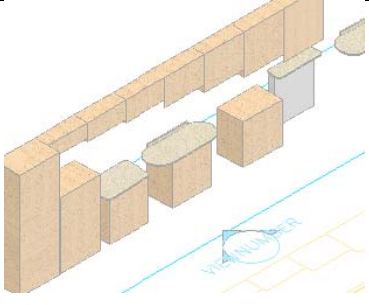
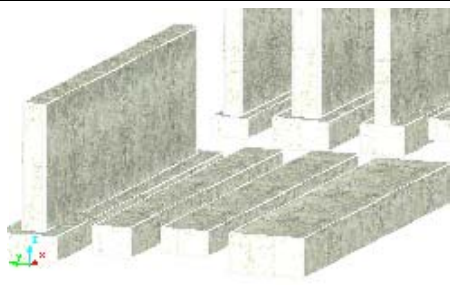
	
<p>Content Browser Casework wall styles</p>	<p>Content Browser Concrete wall styles</p>



While most of the time you will probably use one of these styles as a starting point and just modify it to meet your needs, the exercise in this section shows you how to create a casework wall style from scratch to reinforce each of the important aspects of these walls styles so that when you go to modify one of the provided styles you will know what controls are important and which you can skip.

David's Sample Content

In addition to the styles provided by the software, in the dataset drawing for the exercise I have provided a few more styles for you to take a look at.

Walls as cabinetry styles

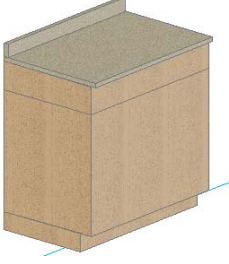
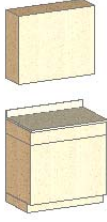
There are three styles in the Class dataset drawing AB304-3_Walls not Walls Part 2.dwg

		
<p>Style name: 4D Casework-36 (Base with Counter- drawer and kick)</p>	<p>Style name: 4d Casework-Bottom and Uppers</p>	<p>Style name: Casework-36 carried away with components</p>
<p>A modification of one of provided styles adding in the toe kick and the drawer line.</p>	<p>This is the first style with an additional component to represent the upper cabinet.</p>	<p>This is just an example of too much of a good thing.</p>

I use the wall style 4D Casework-36 (Base with Counter- drawer and kick) in preliminary layouts of casework areas (labs, kitchens). Once an elevation is generated, the kick and top drawer lines are already in the elevation I just need add the vertical elements, lower drawers, and swing chevrons to complete the interior elevation.

Walls as footing styles

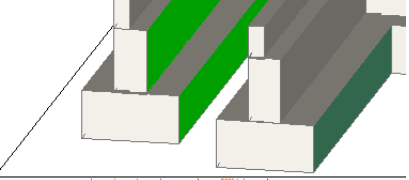
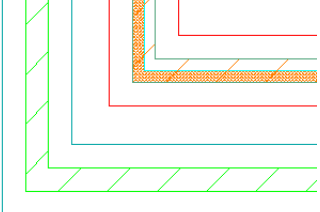
	<p>4d_Foundation 1 differs from the provided content in that the bottom of the wall is set by the wall bottom rather than the baseline. You can use the floor line offset to create stepped footings.</p>
	<p>Wall Style 4D_Foundation 2 is similar, but modifies the cut plane to enable hatching of both the 8" stem wall and the 4" capping block</p>



Exercise: Creating a Casework Wall from Scratch

This Exercise creates a wall like the 4d Casework-Bottom and Uppers style provided in the drawing. While it would be easiest to create this style by modifying one of the provided styles from the tool catalog, I am creating it from scratch here to emphasize the important settings and concepts to keep in mind when working with any type of vertically stacked wall.

Create a new wall style

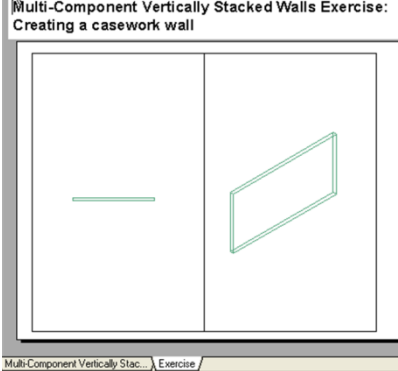
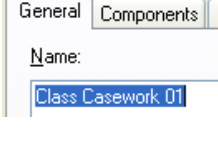
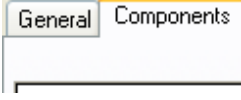
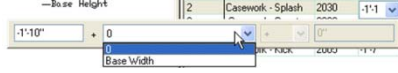
In this section you will create a new style wall and set the basic settings for one component of the wall style. After you have set the basic setting you will use the Add component button to add all the components for the walls style.

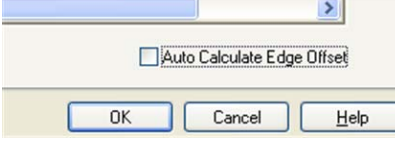
Step	Image	Comments						
<p>Open the dataset drawing AB304-3_Walls not Walls Part 2.dwg and select the standard wall that is visible in the Exercise layout tab.</p>	 <p>Multi-Component Vertically Stacked Walls Exercise: Creating a casework wall</p>							
<p>Right Click this selected wall and pick Copy Wall Style and Assign to access the new style's properties dialog box</p>								
<p>In the General tab, rename the new style to Class Casework 01. Add a description if you wish</p>								
<p>On the components tab, set the following parameters for component index number 1:</p>								
<p>Name = Casework Priority = 2000</p>	<table border="1" data-bbox="618 1075 954 1167"> <thead> <tr> <th>Index</th> <th>Name</th> <th>Priority</th> </tr> </thead> <tbody> <tr> <td>1</td> <td>Casework - Upper</td> <td>2000</td> </tr> </tbody> </table>	Index	Name	Priority	1	Casework - Upper	2000	<p>The name you give a component will appear in the display properties and other areas of the style dialog box.</p> <p>The Priority determines which components will clean up with other walls.</p>
Index	Name	Priority						
1	Casework - Upper	2000						
<p>Width = -1'-10"</p>	 <p>To eliminate the BW in both width and edge offset you need pick in the component width area and use the drop down arrow to access the formula area, change the BASE WIDTH to 0</p>	<p>The width of negative 1'-10" offsets this component in a negative direction from the two pick points when drawn from left to right. This means this wall (as true of all supplied ACA walls) will be drawn clockwise around the inside of the room.</p>						
<p>Edge offset = 0 Function = Non Structural or – Dimension outer edges checked</p>	<table border="1" data-bbox="618 1673 1013 1772"> <thead> <tr> <th>Edge Offset</th> <th>Function</th> <th>Dimension</th> </tr> </thead> <tbody> <tr> <td>0"</td> <td>Non-Structural</td> <td><input checked="" type="checkbox"/> <input type="checkbox"/> <input checked="" type="checkbox"/></td> </tr> </tbody> </table>	Edge Offset	Function	Dimension	0"	Non-Structural	<input checked="" type="checkbox"/> <input type="checkbox"/> <input checked="" type="checkbox"/>	<p>The edge offset is again a distance measured from the two points picked in the drawing to create a baseline justified wall.</p>
Edge Offset	Function	Dimension						
0"	Non-Structural	<input checked="" type="checkbox"/> <input type="checkbox"/> <input checked="" type="checkbox"/>						

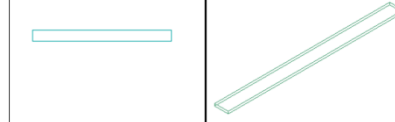
<p>Bottom Elevation = 0 from baseline Top Elevation = 4" from Baseline</p>	<table border="1"> <thead> <tr> <th colspan="2">Bottom Elevation</th> <th colspan="2">Top Elevation</th> </tr> <tr> <th>Offset</th> <th>From</th> <th>Offset</th> <th>From</th> </tr> </thead> <tbody> <tr> <td>0"</td> <td>Baseline</td> <td>4"</td> <td>Baseline</td> </tr> </tbody> </table>	Bottom Elevation		Top Elevation		Offset	From	Offset	From	0"	Baseline	4"	Baseline	
Bottom Elevation		Top Elevation												
Offset	From	Offset	From											
0"	Baseline	4"	Baseline											
<p>Verify the Auto Calculate edge offset is turned off at the lower right corner of the dialog box</p>		<p>AutoCalculate will add the width of the currently selected component to the edge offset of the new component</p>												
<p>Click the Add component button in the upper right corner of this dialog box 4 times</p>		<p>You should have 5 total components to the wall</p>												
<p>Click OK to return to the drawing and save your work</p>		<p>The project at this point has 5 components 22" wide and 4" tall all stacked on top of one another</p>												

TIP: As you add components to a wall, it will use the currently selected component as a "template" and copies all the values into the new component



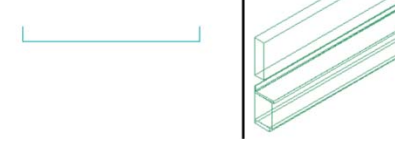

Adjust the wall components

In this section you will adjust the wall components parameters to create the vertical stacking.

<p>Select the wall, right click and choose Edit Wall style from the pop up menu</p>																																																						
<p>On the Components tab make the following changes:</p>																																																						
<p>Rename the components as shown Set the priorities as shown Set the Widths as shown</p>	<table border="1"> <thead> <tr> <th>Index</th> <th>Name</th> <th>Priority</th> <th>Width</th> </tr> </thead> <tbody> <tr> <td>1</td> <td>Casework - Upper</td> <td>2000</td> <td>-1'-0"</td> </tr> <tr> <td>2</td> <td>Casework - Splash</td> <td>2030</td> <td>-3/4"</td> </tr> <tr> <td>3</td> <td>Casework - Counter</td> <td>2020</td> <td>-2'-0"</td> </tr> <tr> <td>4</td> <td>Casework - Lower</td> <td>2010</td> <td>-1'-10"</td> </tr> <tr> <td>5</td> <td>Casework - Kick</td> <td>2005</td> <td>-1'-7"</td> </tr> </tbody> </table>	Index	Name	Priority	Width	1	Casework - Upper	2000	-1'-0"	2	Casework - Splash	2030	-3/4"	3	Casework - Counter	2020	-2'-0"	4	Casework - Lower	2010	-1'-10"	5	Casework - Kick	2005	-1'-7"	<p>These priorities work with the casework styles supplied in the Content Browser Catalogs</p>																												
Index	Name	Priority	Width																																																			
1	Casework - Upper	2000	-1'-0"																																																			
2	Casework - Splash	2030	-3/4"																																																			
3	Casework - Counter	2020	-2'-0"																																																			
4	Casework - Lower	2010	-1'-10"																																																			
5	Casework - Kick	2005	-1'-7"																																																			
<p>Set the bottom and top elevation settings as shown at right</p>	<table border="1"> <thead> <tr> <th>Index</th> <th>Name</th> <th>W</th> <th>H</th> </tr> </thead> <tbody> <tr> <td>1</td> <td>Casework - Upper</td> <td>...</td> <td>...</td> </tr> <tr> <td>2</td> <td>Casework - Splash</td> <td>...</td> <td>...</td> </tr> <tr> <td>3</td> <td>Casework - Counter</td> <td>...</td> <td>...</td> </tr> <tr> <td>4</td> <td>Casework - Lower</td> <td>...</td> <td>...</td> </tr> <tr> <td>5</td> <td>Casework - Kick</td> <td>...</td> <td>...</td> </tr> </tbody> </table>	Index	Name	W	H	1	Casework - Upper	2	Casework - Splash	3	Casework - Counter	4	Casework - Lower	5	Casework - Kick	<table border="1"> <thead> <tr> <th colspan="2">Bottom Elevation</th> <th colspan="2">Top Elevation</th> </tr> <tr> <th>Offset</th> <th>From</th> <th>Offset</th> <th>From</th> </tr> </thead> <tbody> <tr> <td><input checked="" type="checkbox"/></td> <td>4'-6"</td> <td>Baseline</td> <td>0"</td> </tr> <tr> <td><input checked="" type="checkbox"/></td> <td>3'-0"</td> <td>Baseline</td> <td>3'-6"</td> </tr> <tr> <td><input checked="" type="checkbox"/></td> <td>2'-10"</td> <td>Baseline</td> <td>3'-0"</td> </tr> <tr> <td><input checked="" type="checkbox"/></td> <td>4"</td> <td>Baseline</td> <td>2'-10"</td> </tr> <tr> <td><input type="checkbox"/></td> <td>0"</td> <td>Baseline</td> <td>4"</td> </tr> </tbody> </table>	Bottom Elevation		Top Elevation		Offset	From	Offset	From	<input checked="" type="checkbox"/>	4'-6"	Baseline	0"	<input checked="" type="checkbox"/>	3'-0"	Baseline	3'-6"	<input checked="" type="checkbox"/>	2'-10"	Baseline	3'-0"	<input checked="" type="checkbox"/>	4"	Baseline	2'-10"	<input type="checkbox"/>	0"	Baseline	4"
Index	Name	W	H																																																			
1	Casework - Upper																																																			
2	Casework - Splash																																																			
3	Casework - Counter																																																			
4	Casework - Lower																																																			
5	Casework - Kick																																																			
Bottom Elevation		Top Elevation																																																				
Offset	From	Offset	From																																																			
<input checked="" type="checkbox"/>	4'-6"	Baseline	0"																																																			
<input checked="" type="checkbox"/>	3'-0"	Baseline	3'-6"																																																			
<input checked="" type="checkbox"/>	2'-10"	Baseline	3'-0"																																																			
<input checked="" type="checkbox"/>	4"	Baseline	2'-10"																																																			
<input type="checkbox"/>	0"	Baseline	4"																																																			
<p>Click OK to return to the drawing and save your work</p>		<p>At this point the wall should look like a set of lower and upper shelves in the isometric view, but we still have some work to do on the display representation</p>																																																				

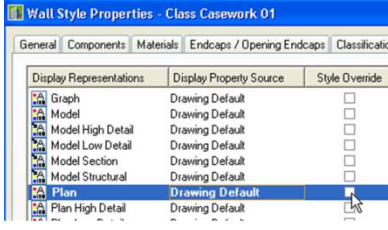
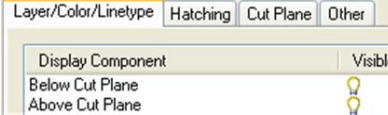
Adjust the plan display representations

In this section you will adjust the display properties of the wall using style overrides.

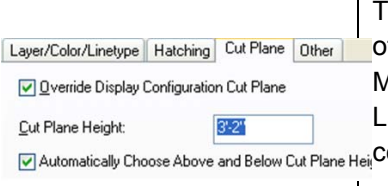
<p>Select the wall, right click and choose Edit Wall style from the pop up menu</p>		
<p>Click the Display Representation tab</p>		
<p>Click the Plan Display representation then click the checkbox under style override.</p>		<p>This is the primary reason to start with one of the existing casework styles and modify it. The existing content styles have the style overrides in place for the standard display representations.</p>
<p>In the Layer/Color/Linetype tab, set the setting to match the image at right.</p>		<p>These setting will show the components below the cut plane as well as the upper cabinets as a hidden green line</p>
<p>Turn off the shrink wrap and verify shrink wrap hatch is off</p>		
<p>Select all the boundaries in the following manner: Click Boundary 1, hold the shift key and click boundary 5, let off the shift key Click the By Material button to open up access to the layer color linetype. Change the setting to those shown at right</p>		<p>By material unchecked Layer = A-Flor-Case Color and Linetype ByLayer or ByBlock</p>
<p>Repeat to turn off all the hatches</p>		
<p>Click the Cut Plane tab</p>		
<p>Place a check in the Override Display Configuration Cut Plane dialog box and set the cut plane height to 3'-2"</p>		<p>This puts the cut plane for all walls of this type through the backsplash. Most of the controls on the Layer/Color/Linetype tab are only considered AT THE CUT PLANE!</p>
<p>Click the Other tab</p>		
<p>Click Display Inner Lines Above</p>		<p>This turns on the upper cabinet</p>

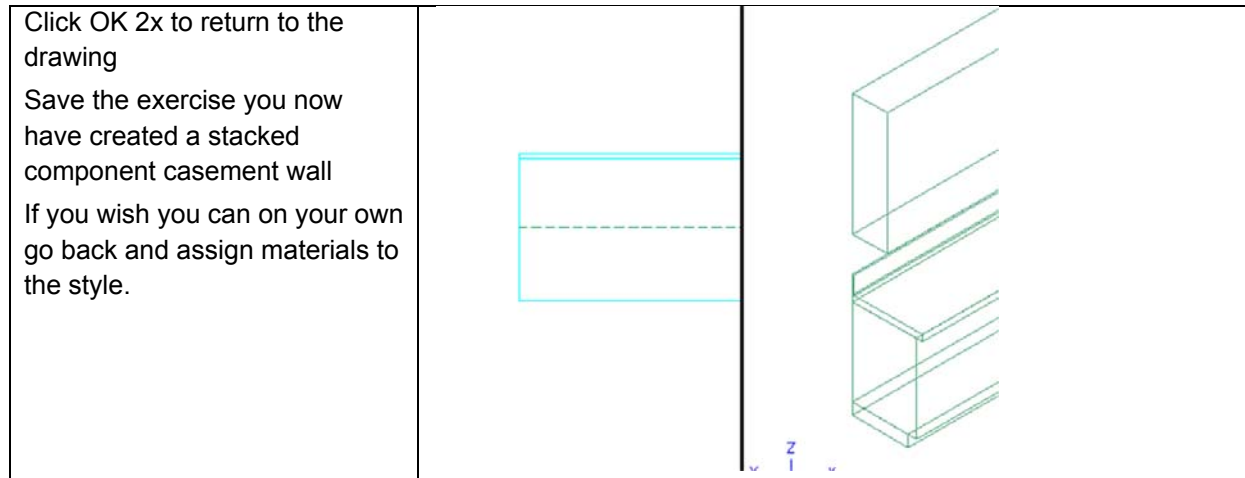

While this plan representation shows the small line at the back side of the cabinet that that is the back splash, on your own experiment with the Manual overrides of above and below cut planes. By adding a 6" (which cuts through the base cabinet) and a 5' to cut through the upper cabinet and lowering the cut plane to 2'-11 you can a cabinet that looks in plan like this:



This is provided to you in the drawing AB304-3_Walls not Walls Part 2 Done.dwg

Tips and Tricks with Vertically Stacked Walls

Copying wall components from one wall style to another:

Use style manager, open source wall style. Select the components (components tab) you wish to copy and drag them into the target style.

Part 3: Walls with Sweeps

A Sweep is a useful tool that allows you to replace any single component in a wall with a predefined shape. Any Closed polyline or multiple closed polylines can be used to generate a Profile that can be swept along a wall.





Concepts and Terms

Profiles:

A profile is your way to get any custom shape into an ACA object. Profiles can be applied to door and window styles, railing styles and many other ACA objects. However most of the general rules of thumb for creating and using profiles are broken when you are using a profile as a sweep along a wall.

Profile Creation:

To Create a profile, right click on a polyline and select Convert To > Profile Definition. At the command line you can enter A to add another ring [read closed polyline, spline, ellipse, or circle]. When you are done adding rings you will then specify an insertion point. This can be a pick on the screen or the default centroid (weighted center of the geometry you just specified).





 <p>A valid shape</p>	 <p>Rings within rings will be usually be interpreted as a void inside a solid</p>	 <p>A profile used by the Content Browser door style Hinged - Double - 6 Panel Half Lite</p>	 <p>Another Valid shape</p>	 <p>The shapes cannot cross each other.</p>
--	---	---	---	--

Profile Insertion Point

For most ACA objects the insertion point does not matter, the profile is just used in the object as it is. This is NOT true for sweeps. Profiles created for sweeps must have a specific insertion point. Generally this will be at the northern edge of the wall component you are going to apply the profile to (remember the native orientation of a wall is drawn from left to right in the world UCS). The sweep can then be moved up and down by adjusting the bottom offset of the swept component in the wall style in the same manner as you adjusted the vertically stacked components in the first exercise.

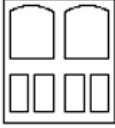
Profiles and Shape Size

Here again sweeps differ from other profile applications within ACA. In general a profile will be distorted to meet the overall size applied to its parent object. Profiles created for wall sweeps will always control the final size and shape of the component they are applied to.



 <p>A profile used by door style Hinged - Double - 6 Panel Half Lite is drawn to size 6' wide</p>	 <p>An elevation view of this door style. 6' wide and 6'-8"</p>	 <p>Same door style 2' wide and 9' tall showing the profile</p>	 <p>A Wall with a brick component with an absolute top</p>	 <p>The same wall with a sweep applied to the brick</p>
--	--	--	---	--

and 6'-8" tall.	tall.	distortion.	height (vertically controlled).	component.
-----------------	-------	-------------	---------------------------------	------------

Profiles orientation

Here again sweeps differ from other profile applications within ACA. In general the geometry for profiles is not direction dependent.

When creating profiles for sweeps the idea of positive is exterior (general ACA walls rule of thumb) falls apart. When drawing the profile for the exterior of a wall such as a brick wainscot draw it facing in the negative direction (to the left in plan view). When drawing interior sweeps, such as ceiling coves, draw using the positive direction (to the right in plan view).



		
A polyline with the profile insertion point shown for an exterior brick wainscot	A polyline with the profile insertion point shown for an interior crown molding	A view from the left side of a wall with these sweeps applied to a wall drawn from left to right





Installed Content:

I am not aware of any predefined samples of sweeps provided with the software.

David's Sample Content

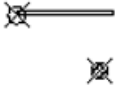
Within the dataset for this class in the drawing AB304-3 When Walls are Not Walls part 3.dwg there are several examples of wall sweeps. I realize that a rod and shelf is not a big issue for many people, but I provide them here to illustrate the basic concepts of using sweeps with walls.

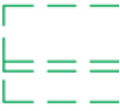
Polylines and insertion points used	Left view	Plan view	Comments
			This sweep is a simple one profile sweep. The insertion point is at the base of the wall. Note you must adjust the display properties for this type of wall either by instance or by style

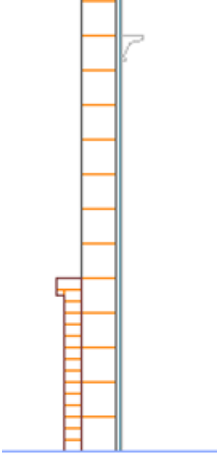
			<p>A rod and shelf created with 2 sweeps.</p> <p>While on the surface these two samples look very similar, but using 2 different sweeps, you have the ability to move the components relative to each other and the wall by editing the wall style components edge and vertical offsets</p>
			<p>Notice the insertion point of the brick face. It is at the outside edge of the profile shape for an exterior wall sweep.</p>

Exercise Wall Sweeps: Create a Parking Area Curb and Gutter

This exercise takes you through the process of creating a curb and gutter for a parking island.

Create a profile definition for the curb

As you create a profile definition WATCH THE COMMAND LINE!

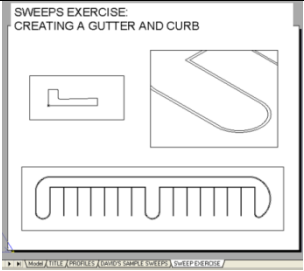
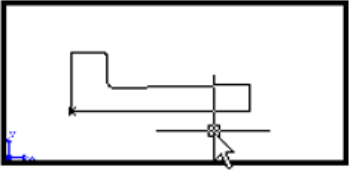
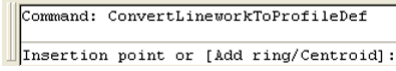
<i>Step</i>	<i>Image</i>	<i>Comments</i>
<p>Open the dataset drawing BD24-2 Walls not Walls part 2.dwg and make SWEEP EXERCISE layout tab current.</p>		
<p>Activate the upper left viewport.</p>		<p>The closed polyline to be used for the profile is already created for you.</p>
<p>Select the polyline and choose Convert To > Profile Definition from the right click pop-up menu</p>		<p>The command line is now asking you to either: 1) pick an insertion point</p>

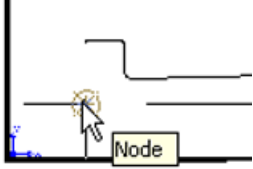
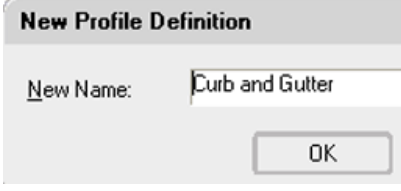
		Or 2) Use the Centroid as the insertion point (C for Centroid) Or 3) Pick another closed polyline (A for Add Ring),
Use the node osnap to pick the node at the lower left hand corner of the polyline or just use the end point osnap to pick this corner		
[Enter] to accept the default <New> command line prompt		
Type Curb and Gutter for the new name, then click OK to return to the drawing		
Save your work to this point		At this point the profile definition exists and you can erase the polyline that generated the profile if you wish.

Create a polyline from the curbing linework

This section just takes you through using the BPoly command to create a polyline around the outer edge of the curb. The purpose of this section is to get a singular polyline around the exterior of the parking island. That polyline will then be converted to a wall which will be swept the the profile you just created. There are other ways to generate this polyline such as using the join command or simply drawing a polyline. If you want to use these any of these methods, be aware that the bpoly command will generate a counter clockwise polyline. This will have implications when you convert it to walls later.

<i>Step</i>	<i>Image</i>	<i>Comments</i>
Make the lower viewport current		You may want to zoom in a bit so you can see the space between the two curb lines. However do not zoom in so far that any of the island is off the screen.
Type bpoly at the command line and [enter]		

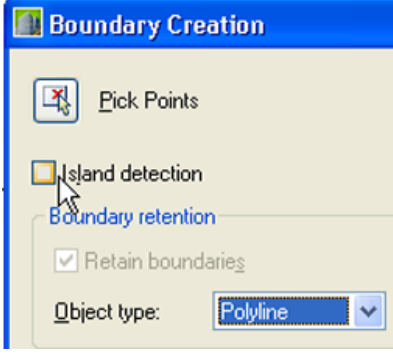
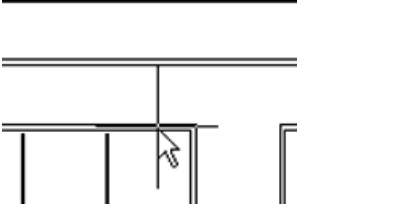
<p>In the Make Region dialog box, uncheck island detection.</p> <p>Verify the object type being generated is a polyline and not a region</p>		
<p>Click the Pick Points button in the upper left of the dialog box</p>		
<p>Pick a point between the two curb lines and then [enter]</p>		<p>You should see the outer edge of the curb highlight before you press the enter key</p>

Convert the polyline to a wall and apply the sweep

This section just takes you through converting the polyline into a wall and applying the sweep to it

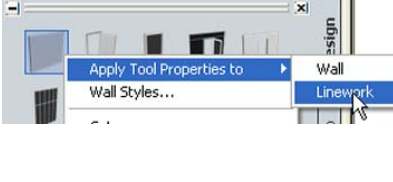
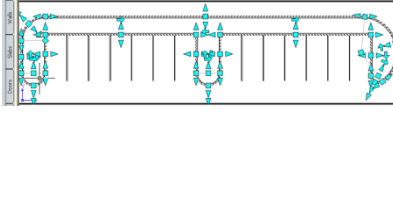
<i>Step</i>	<i>Image</i>	<i>Comments</i>
<p>Make the lower viewport current</p>		
<p>Right click on the standard wall tool from the design tab of the tool palettes.</p> <p>Select Apply Tool Properties to > Linework</p>		
<p>Type in L then [enter]</p>		<p>This is just a standard selection option that picks the last item drawn for you. In this case it should select the polyline that you just created.</p>
<p>[enter] to end the selection set</p>		
<p>[enter] to accept <no> to the erase layout geometry question at the command prompt</p>		
		<p>The polyline is converted to standard wall. All the new walls are highlighted. THIS IS IMPORTANT! Because the next few steps operate on all of the walls. If you deselect the walls</p>

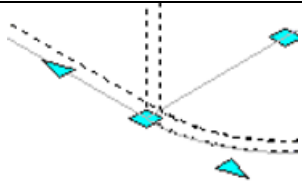
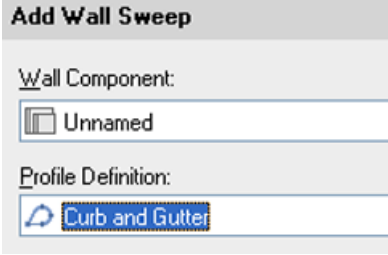
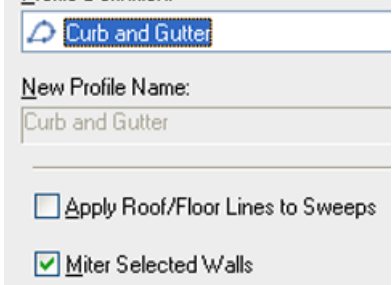
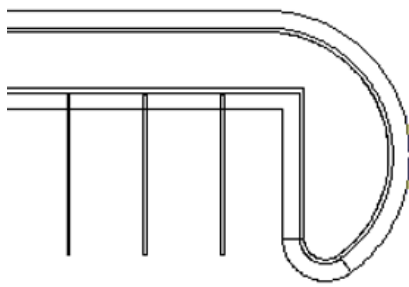
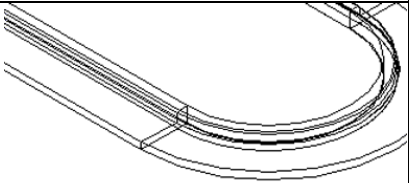
		then you will have to repeat the following steps over and over.
With the walls still highlighted change their properties Justification = right		The walls now lay in the correct location
With all the walls still highlighted, right click and select Sweeps > Add		
Set the profile definition to Curb and Gutter Verify the Miter selected walls is checked. Pick OK		
Save the drawing you now have made a bunch of curbs around a parking island! Exercise Complete!		

Tips and Tricks Sweeps

Redefining profiles

Once you have created a profile, the geometry can be erased from the drawing.

If you need to redefine the profile, most times you can right click the object it is applied to and find some access to editing the profile in place. If the profile has not yet been assigned to anything, then use the Format menu > Profiles > Insert Profile as polyline. This places the definition back into the drawing as a polyline that you can then modify and go through the right click convert process again to redefine the existing definition.

Add selected

Tips: “add selected” will add a wall with the sweep already in place. This is a handy thing when creating multiple instances of the same sweep by replacing the need to sweep each instance of the wall

Removing sweeps:

At the bottom of the properties dialog box of a wall that has a sweep applied is a worksheet that allows you to modify or remove the sweeps applied to the wall.

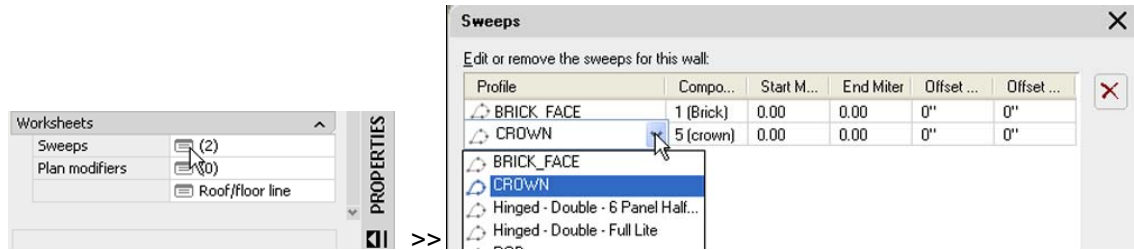

This dialog box allows you to set the miters at the ends (easier done with the right click menu), give an offset from start and end, assign a different profile to the component or delete the sweep entirely

Extra Credit! Curtain walls

Curtain Walls while not entirely walls are also very useful for creating objects in the building model that are not standard AEC object. While an in depth tutorial on curtain walls is outside the scope of this class, I am providing a few examples of Non-Curtain Wall curtain wall objects here in keeping with the spirit of this class. Also note, if you would like to know more about curtain walls and door/window assemblies look for the handout of one of my other classes (See page 2 of this document for reference to download) for a full featured tutorial on curtain walls

Provided in the Datasets for download is AB304-3_Walls not Walls Part 4.dwg. This drawing contains a few sample curtain walls that are not curtain walls:

<p>basic curtain wall</p>		
<p>Glass block curtain walls</p>	<p>Shelving units Downloaded from newsgroup, I forget who posted these, if it was you, email me and I will put your name here!</p>	<p>Chad Ames' quoin and stained glass window</p>

Remember to Think outside the box, and thanks for attending my class!!!

This document and dataset will be available from

www.autodesk.com/auonline or my own sites www.daviddriver.com, www.work4d.com

If you have questions or comments, feel free to email me david@daviddriver.com

Version 1 submitted to AU.